



Electrolux
PROFESSIONAL

Modular Cooking Range Line 900XP 4 Electric Hot Plate Range on Electric Oven - Marine

ITEM # _____

MODEL # _____

NAME # _____

SIS # _____

AIA # _____



391184 (E9ECMH4QE5)

4-Hot electric Plate on Oven
- marine

Short Form Specification

Item No. _____

To be installed on stainless steel feet with height adjustment up to 50 mm. Four 4 kW square cast-iron hot plates hermetically sealed to the one-piece top. Oven chamber with 3 levels of runners to accommodate 2/1 GN shelves (2 steam pans). Ribbed, cast-iron oven base plate. Exterior panels of unit in stainless steel with Scotch Brite finish. Pan supports in heavy duty cast iron. Extra strength work top in heavy duty 2 mm stainless steel. Right-angled side edges to allow flush-fitting junction between units.

Main Features

- Unit to be mounted on stainless steel feet with height adjustment up to 50 mm. Unit can be easily mounted on cantilever systems.
- The four 4kW electric cast-iron hot plates are hermetically sealed to the one piece top and are featured with safety thermostat.
- Base compartment consists of an electric standard oven with 40 mm thick oven door for heat insulation, positioned beneath the base plate.
- Oven chamber with 3 levels of runners to accommodate 2/1 GN shelves (2 steam pans).
- Ribbed cast iron oven base plate.
- Oven to feature separate thermostats for top and bottom elements. Thermostat temperature adjustable from 110°C to 285°C.
- The special design of the control knob system guarantees against water infiltration.
- IPX5 water protection.
- Top configuration allows installation on ambient base only (not possible to install on refrigerated nor freezer base).
- Oven thermostat adjustable from 100 °C to 300 °C.

Construction

- Model has right-angled side edges to allow flush fitting joints between units, eliminating gaps and possible dirt traps.
- AISI 304 stainless steel worktop, 2mm thick.
- All exterior panels in Stainless Steel with Scotch Brite finishing.
- Unit is 930 mm deep to give a larger working surface area.

Included Accessories

- 1 of GN2/1 chrome grid for static oven PNC 164250

Optional Accessories

- GN2/1 chrome grid for static oven PNC 164250
- Pair of cast iron plate bars for electric cooking top PNC 206056
- Junction sealing kit PNC 206086
- Kit 4 wheels - 2 swivelling with brake - it is mandatory to install Base support and wheels PNC 206135
- Flanged feet kit PNC 206136
- Frontal kicking strip for concrete installation, 800mm PNC 206148
- Frontal kicking strip for concrete installation, 1000mm PNC 206150
- Frontal kicking strip for concrete installation, 1200mm PNC 206151

APPROVAL: _____



Experience the Excellence
www.electroluxprofessional.com



• Frontal kicking strip for concrete installation, 1600mm	PNC 206152	<input type="checkbox"/>
• Pair of side kicking strips for concrete installation	PNC 206157	<input type="checkbox"/>
• Frontal kicking strip, 800mm (not for refr-freezer base)	PNC 206176	<input type="checkbox"/>
• Frontal kicking strip, 1000mm (not for refr-freezer base)	PNC 206177	<input type="checkbox"/>
• Frontal kicking strip, 1200mm (not for refr-freezer base)	PNC 206178	<input type="checkbox"/>
• Frontal kicking strip, 1600mm (not for refr-freezer base)	PNC 206179	<input type="checkbox"/>
• Pair of side kicking strips (not for refr-freezer base)	PNC 206180	<input type="checkbox"/>
• 2 panels for service duct for single installation	PNC 206181	<input type="checkbox"/>
• 2 panels for service duct for back to back installation	PNC 206202	<input type="checkbox"/>
• Kit 4 feet for concrete installation (not for 900 line free standing grill)	PNC 206210	<input type="checkbox"/>
• Water column with swivel arm (water column extension not included)	PNC 206289	<input type="checkbox"/>
• Water column extension for 900 line	PNC 206290	<input type="checkbox"/>
• Chimney upstand, 800mm	PNC 206304	<input type="checkbox"/>
• Back handrail 800 mm	PNC 206308	<input type="checkbox"/>
• Back handrail 1200 mm	PNC 206309	<input type="checkbox"/>
• Base support for feet or wheels - 800mm (700/900)	PNC 206367	<input type="checkbox"/>
• Base support for feet or wheels - 1200mm (700/900)	PNC 206368	<input type="checkbox"/>
• Base support for feet or wheels - 1600mm (700/900)	PNC 206369	<input type="checkbox"/>
• Base support for feet or wheels - 2000mm (700/900)	PNC 206370	<input type="checkbox"/>
• Rear paneling - 800mm (700/900)	PNC 206374	<input type="checkbox"/>
• Rear paneling - 1000mm (700/900)	PNC 206375	<input type="checkbox"/>
• Rear paneling - 1200mm (700/900)	PNC 206376	<input type="checkbox"/>
• Chimney grid net, 400mm (700XP/900)	PNC 206400	<input type="checkbox"/>
• Side handrail-right/left hand (900XP)	PNC 216044	<input type="checkbox"/>
• Frontal handrail, 800mm	PNC 216047	<input type="checkbox"/>
• Frontal handrail, 1200mm	PNC 216049	<input type="checkbox"/>
• Frontal handrail, 1600mm	PNC 216050	<input type="checkbox"/>
• 2 side covering panels for free standing appliances	PNC 216134	<input type="checkbox"/>
• Water drain for full module fry tops	PNC 216153	<input type="checkbox"/>
• Large handrail - portioning shelf, 400mm	PNC 216185	<input type="checkbox"/>
• Large handrail - portioning shelf, 800mm	PNC 216186	<input type="checkbox"/>



Front

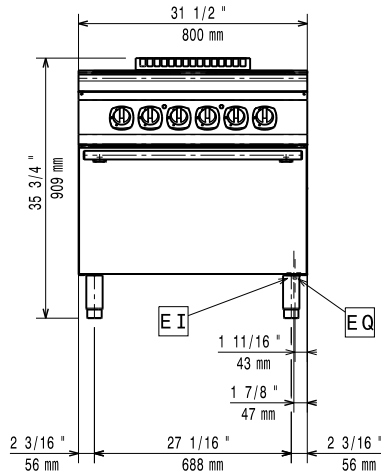

Side

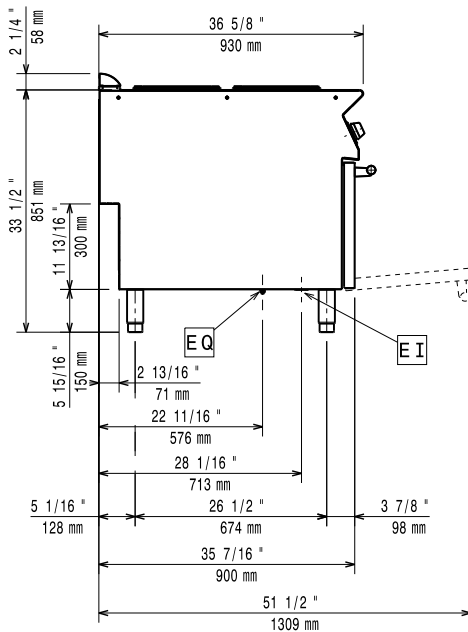

EI = Electrical inlet (power)
 EQ = Equipotential screw

Top

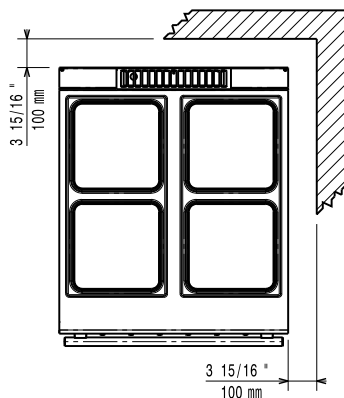

Electric

Supply voltage:	
391184 (E9ECMH4QE5)	400 V/3 ph/50/60 Hz
Electrical power max.:	22 kW
Total Watts:	22

Key Information:

Front Plates Power:	4 - 4 kW
Back Plates Power:	4 - 4 kW
Front Plates dimensions:	300x300 300x300
Back Plates dimensions:	300x300 300x300
Oven Heat Input:	6 kW
Oven working Temperature:	100 °C MIN; 300 °C MAX
Oven Cavity Dimensions (width):	575 mm
Oven Cavity Dimensions (height):	300 mm
Oven Cavity Dimensions (depth):	700 mm
External dimensions, Width:	800 mm
External dimensions, Depth:	930 mm
External dimensions, Height:	850 mm
Net weight:	150 kg
Shipping weight:	149 kg
Shipping height:	1200 mm
Shipping width:	1020 mm
Shipping depth:	860 mm
Shipping volume:	1.05 m ³

If appliance is set up or next to or against temperature sensitive furniture or similar, a safety gap of approximately 150 mm should be maintained or some form of heat insulation fitted.

Certification group: N9CE1